

CABLES T.I.R. et EMBOUTS pour CABLES T.I.R.

T.I.R.-KABELS en EINDSTUKKEN voor T.I.R.-KABELS

T.I.R.-CABLES and STOPENDS for T.I.R.-CABLES

T.I.R.-KABLES und ENDVERSCHLÜSSE für T.I.R.-KABELS



N° 3338 (Ø 6 mm)

N° 3327 (Ø 8 mm)

embout pour cable T.I.R. Ø 8 mm

eindstuk voor T.I.R.-kabels Ø 8 mm

stopend for T.I.R.-cable Ø 8 mm

Endverschlüsse für T.I.R.-Kabel Ø 8 mm



3328



3329 / 13,5
3339 / 11

clou à rivet et œillet ovale en laiton pour dito
messing klinknagel en ovaal oog voor dito
brass nail to be riveted and oval eyelet for dito
Messing Spitzniet und Ovalöse dazu

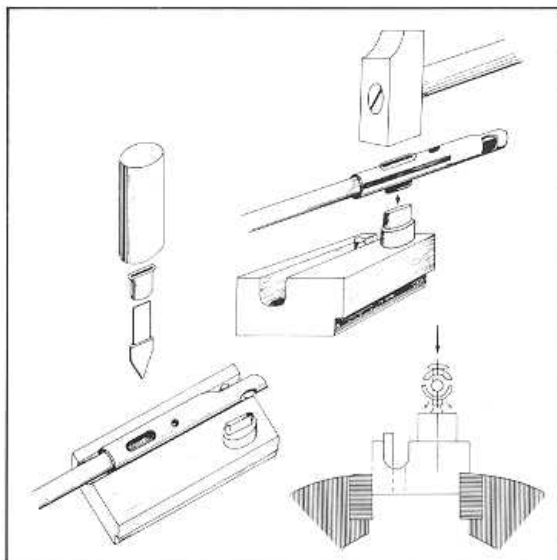

appareil de montage pour dito
montage-set voor dito
setting-tool for cable-stopend
Einschlagwerkzeug dazu

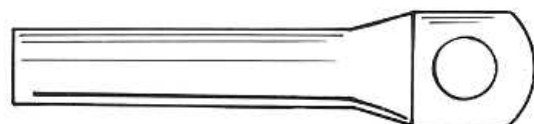

3335/8

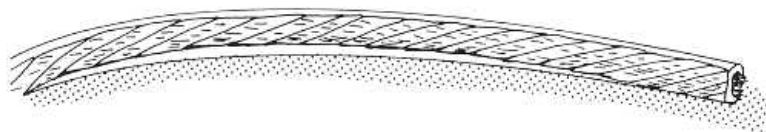

Ø 6 mm PVC/AC

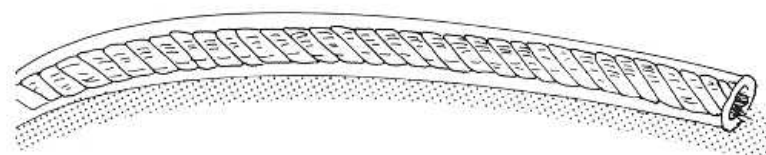

Ø 8 mm PVC/AC

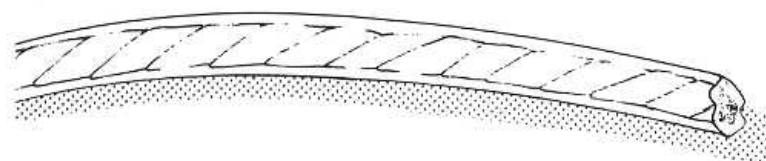

Ø 8 mm SISAL / PVC
Ø 8 mm PVC / PP

AC = acier laitonné
AC = staal vermessingt
AC = steel brassed
AC = eisen vermessingt

PP = polypropylene
PP = polypropyleen
PP = polypropylene
PP = polypropyleen

EMBALLAGE	•	VERPAKKING	•	PACKING	•	VERPACKUNG
100 embouts	+	100 clous	+	100 œillets		
100 eindst.	+	100 nagels	+	100 ogen		
100 stopends	+	100 nails	+	100 eyelets		
100 Endv.	+	100 Nieten	+	100 Ösen		
				Ø 6 mm PVC/AC		
				Ø 8 mm PVC/AC		
				Ø 8 mm PVC/PP	500 m	
						3335/8
						250

3327



USINE UNION

SA
NV BELGIUM

BRUSSELS • ☎ 32 / (0)2 / 344.19.90 • FAX 32 / (0)2 / 343.68.69
TELEX 23.287

EMBOUS pour CORDE et COURROIES T.I.R.

EINDSTUKKEN voor TOUWEN en voor T.I.R. RIEMEN

ROPE-TIPS and STOPENDS for T.I.R. STRAP

SEILKLAMMERN und ENDVERSCHLÜSSE für T.I.R. RIEMEN

monté - set
geplaatst - montiert

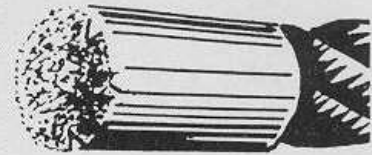
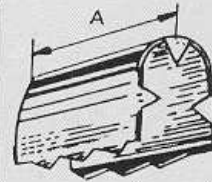

B = Ø corde - touw - rope - Seil

SIMPLES — ENKEL — SINGLE — EINZELN

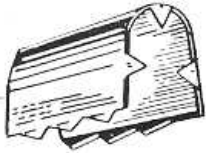

A	20	20	mm
B	8	10	mm
N°	3500/8	3500/10	

DOUBLES — DUBBEL — DOUBLE — DOPPELT

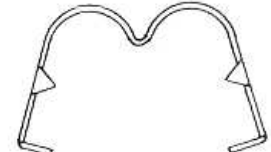
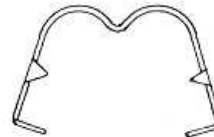

A	27	27	35	mm
B	6	8	10	mm
N°	3501/6	3501/8	3501/10	

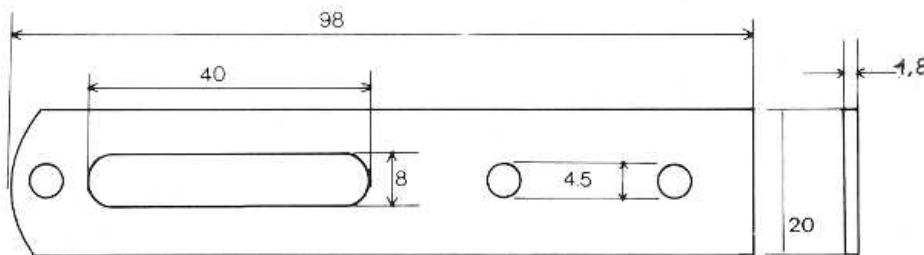

3330



311 D

embout pour courroie T.I.R. (par paire)
eindstuk voor T.I.R.-riem (2-delig)
stopend for T.I.R.-strap (per pair)
Endverschlüsse für T.I.R.-Riemen (2-Teilig)

rivets tubulaires en laiton pour dito
messing buisrivetten voor dito
brass tubular rivets for dito
Messing Hohlnieten dazu

EMBALLAGE	VERPAKKING	PACKING	VERPAKKUNG
100 paires d'embouts + 300 rivets			
100 2-delige eindst. + 300 rivetten	3500/8	3500/10	3501/6 - 3501/8
100 pairs of stopends + 300 rivets	1.000	500	250
100 2-Teilige Endv. + 300 Hohln.			100
3330			



USINE UNION SA NV BELGIUM

BRUSSELS • ☎ 32 / (0)2 / 344.19.90 • FAX 32 / (0)2 / 343.68.69
TELEX 23.287