

**CROCHETS pour BACHES et CAMIONS**

**HAKEN voor ZEILEN en VRACHTWAGENS**

**HOOKS for SAILS and TRUCKS**

**HAKEN für PLANEN und KRAFTWAGEN**

**CROCHET TRIANGULAIRE DE CARROSSERIE  
DRIEHOEKIGE KARROSSERIEHAAK  
TRIANGULAR TRUCKHOOK  
DREIECKIGE KAROSSERIEHAKEN**

**CROCHET DE CORDAGE  
KOORDHAAK  
STRINGHOOK  
SEILHAKEN**

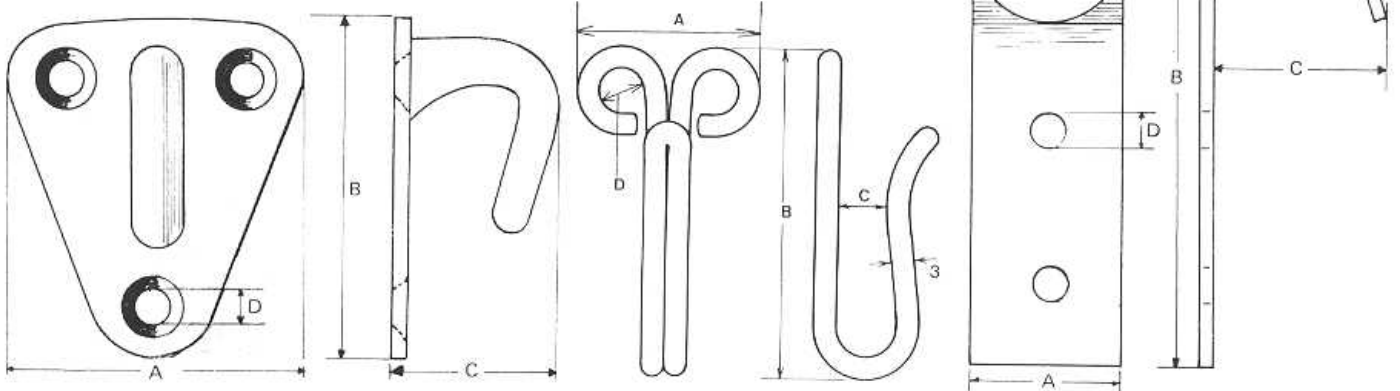

A	39	23,4	20	mm
B	45	43,4	73	mm
C	23	5,7	25	mm
D	5,6	5,6	4,3	mm
N°	<b>3331</b>	<b>2041</b>	<b>3319/70</b>	

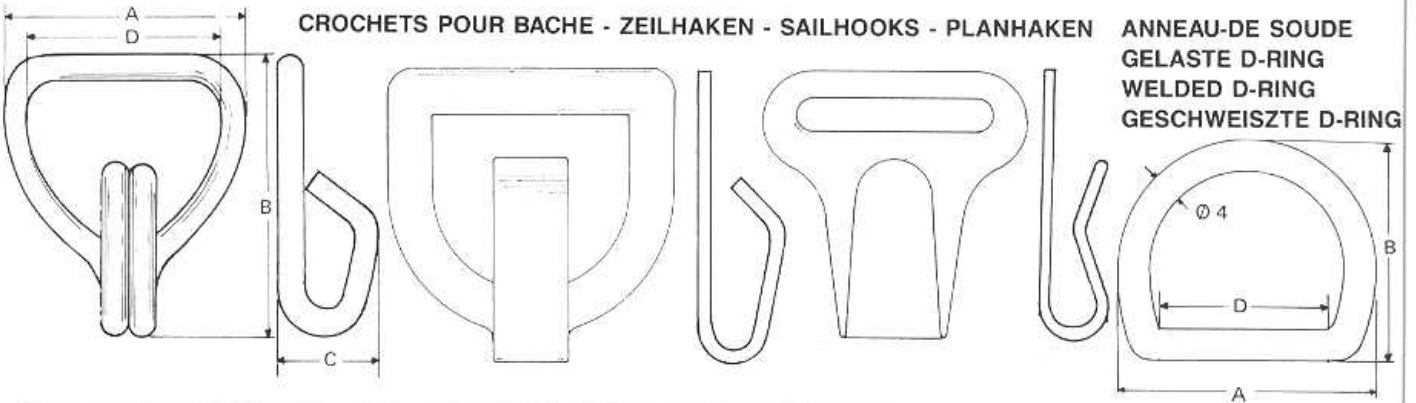

A	33	38	36	36	mm
B	42	41	35	29	mm
C	14	13	11		mm
D	25,5	25,8	26	26	mm
N°	<b>3332</b>	<b>3320</b>	<b>3321</b>	<b>5350/25</b>	<b>Ø4</b>

**EMBALLAGE • VERPAKKING • PACKING • VERPACKUNG**

**3319/70 - 3332 - 3320 - 3321 - 3331**  
100

**2041**  
250

**5350/25**  
500

**CROCHETS pour BACHES et CAMIONS**

**HAKEN voor ZEILEN en VRACHTWAGENS**

**HOOKS for SAILS and TRUCKS**

**HAKEN für PLANEN und KRAFTWAGEN**

**CROCHET A 4 GRIFFES + CONTRE-PLAQUE**  
**VIERPUNTSHAAK + TEGENPLAAT**  
**FOURPOINTSHOOK + BACKPLATE**  
**VIERSTICHHAKEN + GEGENPLATTE**

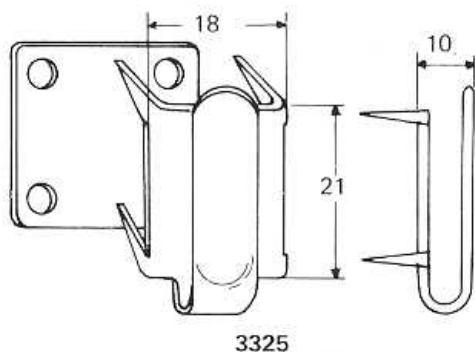

3325

**ETRIER DE SUSPENSION**  
**OPHANGBEUGEL**  
**SUSPENSIONSTIRRUP**  
**AUFHÄNGEBÜGEL**

à utiliser avec des anneaux ronds soudé ;  $\varnothing$  45 et 60 mm. intérieur sont courants pour cet usage.

te gebruiken met gelaste ronde ringen ;  $\varnothing$  45 en 60 mm. binnenmaat zijn courant voor deze toepassing.

to be used with welded round rings ;  $\varnothing$  45 and 60 mm. interior are usual for this application.

zu verwenden mit geschweiszte rund Ringe ;  $\varnothing$  45 und 60 mm. Lichtweite sind üblich für diese Verwendung.

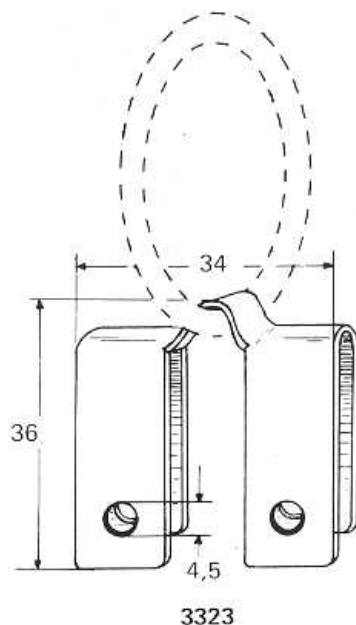

3323

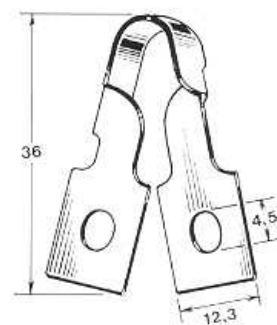
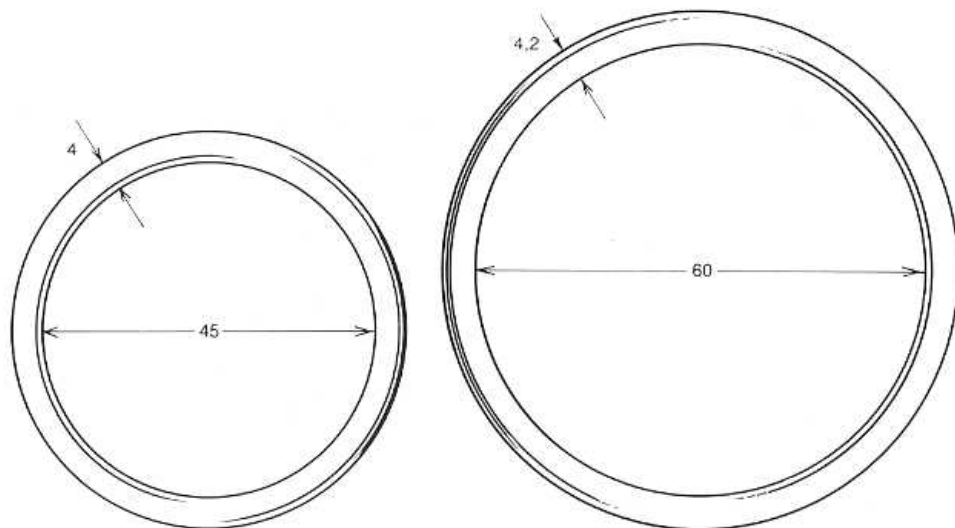

A	45	60	mm
B	4	4,2	mm
N°	5200/45/SD	5200/60/SD	3336

EMBALLAGE

VERPAKKING

PACKING

VERPACKUNG

3323 - 3325 - 5200/45/SD - 5200/60/SD

100

3336

500



**USINE UNION** SA NV BELGIUM

BRUSSELS • 32 / (0)2 / 344.19.90 • FAX 32 / (0)2 / 343.68.69  
 TELEX 23.287